

The **STATE**
OF THE ARC™

SEAMLESS HDPE
ARC™ BENDS



PIPESTAR
AFRICA

March 2026



Major Features:

Pipestar Africa offers a range of seamless long radius ARC™ HDPE sweep bends made to the highest quality standards.

Pipestar Africa offers a range of seamless, HDPE ARC™ Bends produced through a unique patented manufacturing process. The name ARC™ comes from the word ARChetype which means “original pattern or model of which all things of the same type are representations or copies.” ARC™ sweep bends are hot forged from polyethylene PE 100 pressure pipes.

- Improved roundness
- Seamless Smooth Interior
- No flow restriction
- Fully pressure rated
- Wearability increased in slurry lines
- Can manufacture any angles up to 90°
- Suitable for butt-welding, electrofusion or flanging
- Improved welding times
- Improved pumping efficiency



Industry Applications of ARC™ HDPE Sweep Bends

- ✓ Tailings
- ✓ Mines
- ✓ Paper Board Mills
- ✓ Chemical Works
- ✓ Water Supply – Treatment
- ✓ Fire Ring Mains
- ✓ Sewage – Gravity, Pressure & Vacuum
- ✓ Food Processing
- ✓ Thermal Generating Plants
- ✓ Steel Plants
- ✓ Hydro Generating
- ✓ Mechanical Contracting
- ✓ Saw Mills
- ✓ Civil Engineering
- ✓ Oil Refineries
- ✓ Irrigation
- ✓ Gas Distribution
- ✓ Conduit
- ✓ Coal Beneficiation
- ✓ Slurry Lines

BENDS

ARC™ Bends Manufactured to:

- Angular tolerance of $\pm 5^\circ$
- Linear tolerance of $\pm 20\text{mm}$
- Centre line of curvature 3 times the pipe diameter

Long Radius Sweep Bend Specifications

SANS / ISO 4427 and SANS / ISO 4437



PIPESTAR
AFRICA

General bend specifications for design engineers

- Manufactured in one continuous piece from HDPE PE 100 pressure pipe
- Centre line radius of curvature 3 x diameter
- Meets Pipestar Africa published dimensional schedule. Dimensional tolerance $\pm 20\text{mm}$
- Outside diameter of the spigot ends shall meet the requirements of ISO 4427/4437. Spigot lengths suitable for butt welding or electrofusion
- The bending process will result in a single piece bend at the angle specified by the engineer, with an angular tolerance $\pm 5^\circ$
- The bends will be shipped to site loose or palletized.
- Fittings shall be examined for defects by visual inspection in the first instance, or by any other inspection method if required
- Bends should maintain roundness throughout curvature

Freedom from Defects

- The manufacturing process shall not create any grooves, blisters, or other visual defects on the outside surface of the bend
- There shall be no cavities, voids or inclusions in the fittings body and the inside surface shall be smooth, clean and free from grooves or blisters

Marking

All fittings shall be clearly marked with at least the following information:

- Manufacturers name or Trade mark
- Identification of the material type
- Designated angle of bend
- Outside diameter, SDR and angle of the pipe for which the fitting is intended
- Raw material batch traceability



3D LONG RADIUS ARC™ BENDS

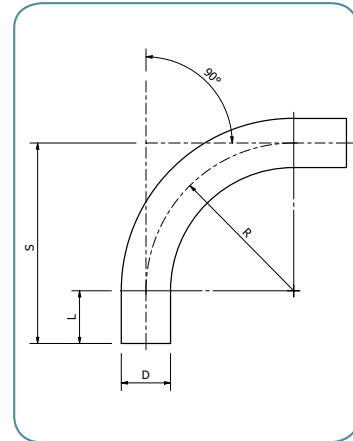
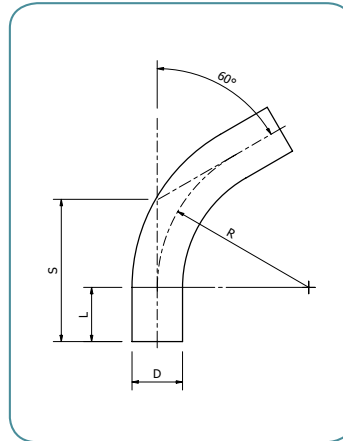
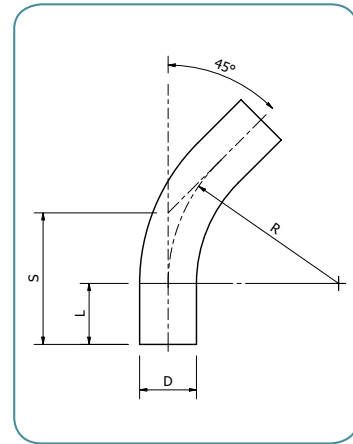
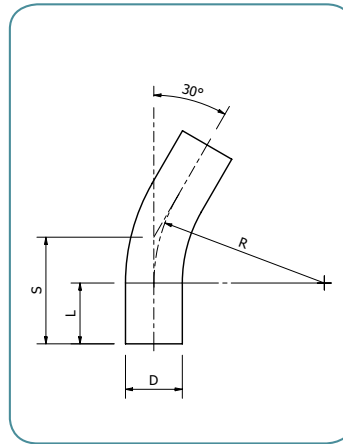

3D LONG RADIUS ARC™ BENDS

D	L	R	S-30°	S-45°	S-60°	S-90°
mm	mm	mm	mm	mm	mm	mm
50	80	150	-	142	-	230
63	80	189	-	158	-	269
75	80	225	-	173	-	305
90	150	270	222	262	306	420
110	150	330	238	287	341	480
125	150	375	250	305	367	525
140	175	420	288	349	417	595
160	200	480	329	399	477	680
180	200	540	345	424	512	740
200	225	600	386	474	571	825
225	270	675	451	550	660	945
250	270	750	471	581	703	1020
280	300	840	525	648	785	1140
315	420	945	673	811	966	1365
355	420	1065	705	861	1035	1485
400	370	1200	692	867	1063	1570
450	400	1350	762	959	1179	1750
500	480	1500	882	1101	1346	1980
560	520	1680	970	1216	1490	2200

Ongoing engineering design efforts may affect the technical information listed in our publications.
Other SDR's available on request.

BUTT WELD SHORT STUBS



PIPESTAR
AFRICA

BUTT WELD / SHORT SPIGOT STUBS

d	d3	d4	le1	h1	z1	Weight SDR17	Weight SDR11
mm	mm	mm	mm	mm	mm	kg	kg
50	63	83	15	20	50	0,09	0,10
63	74	98	15	20	50	0,13	0,14
75	86	110	15	20	50	0,17	0,19
90	103	129	15	20	50	0,23	0,26
110	127	158	18	27	60	0,41	0,47
125	133	158	18	27	60	0,38	0,46
140	157	186	18	27	60	0,54	0,64
160	177	217	15	35	65	0,89	1,03
180	188	217	20	35	70	0,80	0,99
200	217	270	20	35	70	1,54	1,81
225	233	270	20	45	80	1,46	1,78
250	267	320	30	45	90	2,28	2,70
280	288	320	30	45	90	2,06	2,66
315	330	370	30	55	100	3,34	4,17
355	373	430	30	60	110	5,15	6,31
400	427	482	30	65	110	6,65	8,13
450	474	540	30	65	110	8,10	9,98
500	530	585	30	70	115	9,99	12,40
560	592	645	30	70	115	11,81	14,83
630*	642	685	30	70	115	11,76	15,60
630**	642	725	30	70	115	14,87	18,71
710	737	800	30	70	115	14,87	18,71
800	840	905	30	70	115	21,48	24,46
900	945	1005	30	70	120	27,91	36,10
1000	1047	1110	30	70	140	37,93	49,48

- CNC machined from extruded PE100 hollow bar
- Custom dimensions available upon request
- Free from cavities
- Full traceability on raw materials used in production



* 630 HDPE STUB; FLANGES: SANS1123-T1000 (725 PCD); ASA 150#

** 630 HDPE STUB; FLANGES: B/S T/D; SANS1123-T1000 (780 PCD); SANS1123-T1600; SANS1123-T2500

Ongoing engineering design efforts may affect the technical information listed in our publications.

Other SDR's available on request.

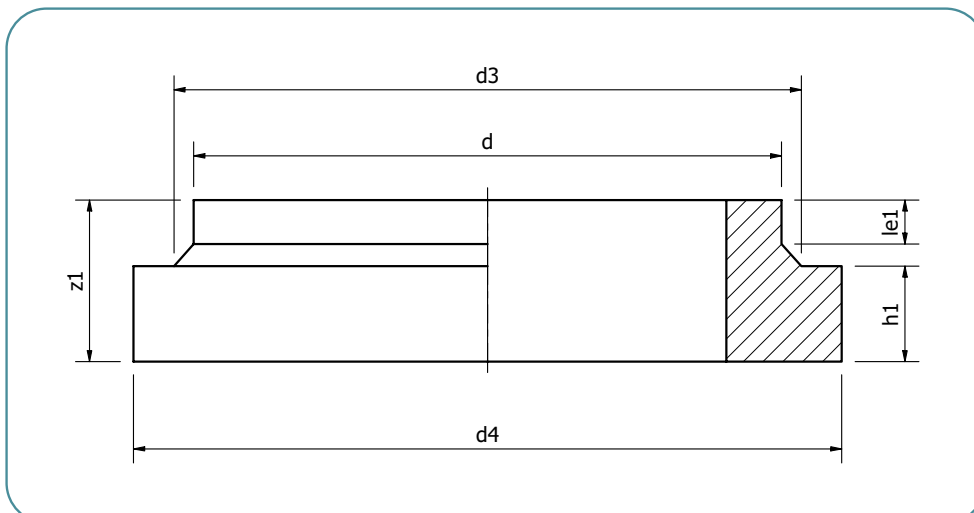

ELONGATED STUBS

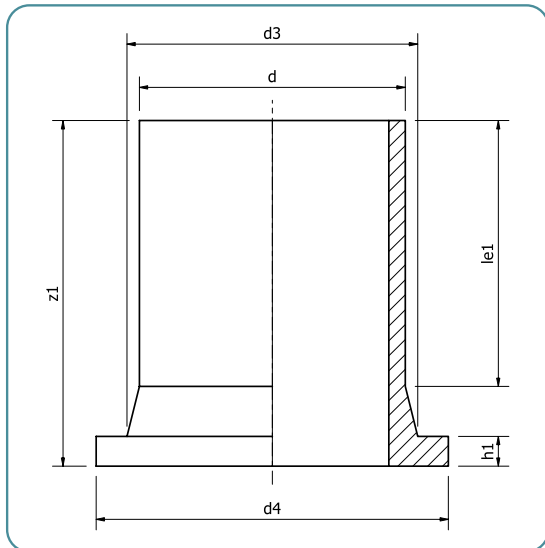

ELONGATED STUBS

d	d3	d4	le1	z1	h1	Weight
mm	mm	mm	mm	mm	mm	kg
SDR17						
50	63	83	77	112	20	0,12
63	74	98	88	123	20	0,18
75	86	110	94	129	20	0,23
90	103	129	100	138	20	0,34
110	125	158	113	158	18	0,54
125	132	158	122	170	18	0,61
140	153	188	130	173	18	0,83
160	175	212	160	208	18	1,24
180	186	212	140	200	20	1,34
200	232	268	133	199	24	2,17
225	235	268	135	201	24	2,22
250	285	320	148	220	25	3,44
280	291	320	154	230	25	3,68
315	335	370	166	242	25	5,09
355	373	430	170	240	40	7,14
400	427	482	180	266	46	10,16
450	474	540	190	295	60	14,48
500	530	585	200	310	60	18,10
560	592	645	320	405	70	27,50
630*	642	685	305	390	70	30,60
630**	662	725	305	390	70	33,55
710	737	800	355	440	70	46,10
800	840	905	425	510	70	66,20
900	945	1005	435	525	70	84,60
1000	1047	1110	470	580	70	114,20
SDR11						
50	63	83	77	112	20	0,15
63	74	98	88	123	20	0,22
75	86	110	94	129	20	0,29
90	103	129	100	138	20	0,44
110	125	158	113	160	18	0,71
125	132	158	116	170	25	0,88
140	155	188	128	182	25	1,26
160	175	212	155	208	25	1,79
180	186	212	168	202	30	1,97
200	232	268	140	206	32	3,06
225	235	268	135	201	32	3,19
250	285	320	138	219	35	4,88
280	291	320	152	231	35	5,37
315	335	370	158	239	35	7,29
355	373	430	170	240	40	9,67
400	427	482	180	266	46	13,74
450	474	540	190	295	60	19,51
500	530	585	200	310	60	24,60
560	592	645	320	405	70	38,50
630*	642	685	305	390	70	43,60
630**	662	725	305	390	70	46,55
710	737	800	355	440	70	64,70
800	840	905	425	510	70	93,60
900	945	1005	435	525	70	120,50
1000	1047	1110	470	580	70	162,10

* 630 HDPE STUB: FLANGES: SANS1123-T1000 (725 PCD); ASA 150#

** 630 HDPE STUB: FLANGES: B/S T/D; SANS1123-T1000 (780 PCD); SANS1123-T1600; SANS1123-T2500

Ongoing engineering design efforts may affect the technical information listed in our publications.

Other SDR's available on request

TAK STUBS



PIPESTAR
AFRICA

TAK STUBS

d	d3	d4	le1	le2	h1	z1	SDR	Weight SDR17	Weight SDR11
mm	mm	mm	mm	mm	mm	mm		kg	kg
50	62	68,5	22	10	16	48	11 17	0,06	0,07
63	85	97	20	15	16	51	11 17	0,14	0,15
75	90	97	20	15	16	51	11 17	0,12	0,15
90	115	124,5	24,5	15	16,5	56	11 17	0,23	0,27
110	115	124,5	24,5	15	16,5	56	11 17	0,17	0,23
125	161	178,5	14	15	17	46	17	0,45	-
140	161	178,5	14	15	17	46	11 17	0,38	0,46
160	160	160	0	29	17	46	11 17	0,29	0,39
200	218	231,5	43	21	21	85	11 17	0,92	1,21
225	273	286	43	21	21	85	17	1,62	-
250	273	286	43	21	21	85	11 17	1,41	1,86

Ongoing engineering design efforts may affect the technical information listed in our publications.
Other SDR's available on request.

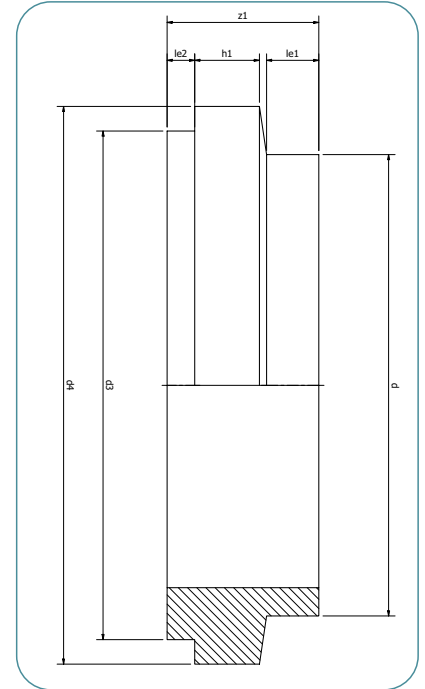

SHOULDERED STUBS

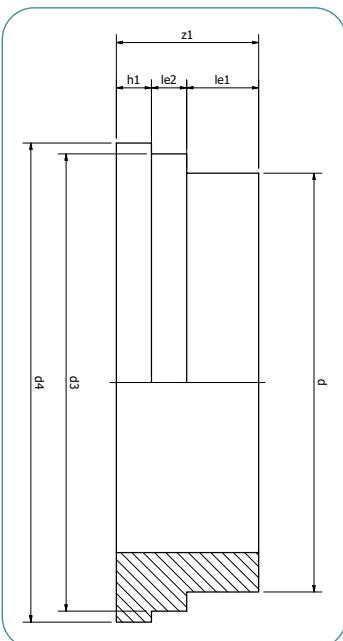

SHOULDERED STUBS

d	d3	d4	le1	le2	h1	z1	SDR	Weight SDR17	Weight SDR11
mm	mm	mm	mm	mm	mm	mm		kg	kg
50	62	68,5	22	10	16	48	11 17	0,06	0,07
63	85	97	20	15	16	51	11 17	0,14	0,15
75	90	97	20	15	16	51	11 17	0,12	0,15
90	115	124,5	24,5	15	16,5	56	11 17	0,23	0,27
110	115	124,5	24,5	15	16,5	56	11 17	0,17	0,23
125	161	178,5	14	15	17	46	17	0,45	-
140	161	178,5	14	15	17	46	11 17	0,38	0,46
160	160	160	0	29	17	46	11 17	0,29	0,39
200	218	231,5	43	21	21	85	11 17	0,92	1,21
225	273	286	43	21	21	85	17	1,62	-
250	273	286	43	21	21	85	11 17	1,41	1,86

To be used with mechanical jointing systems.

Ongoing engineering design efforts may affect the technical information listed in our publications.
Other SDR's available on request.

BUTT WELD CONCENTRIC REDUCERS

BUTT WELD CONCENTRIC REDUCERS

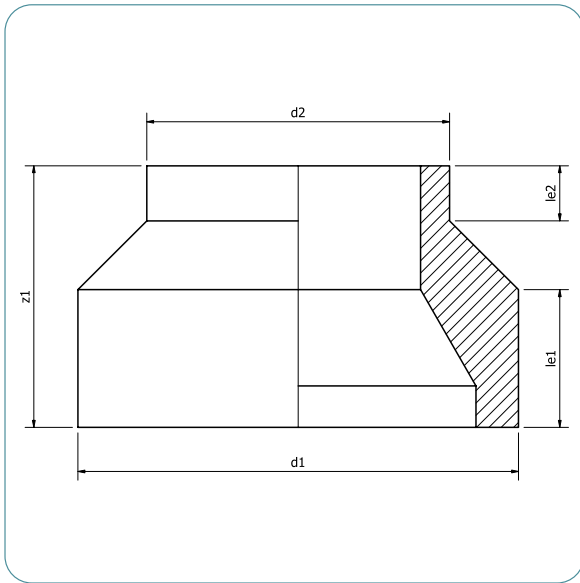

d1	d2	le1	le2	z1	SDR	Weight SDR17	Weight SDR11
mm	mm	mm	mm	mm		kg	kg
63	50	32	25	90	11 17	0,07	0,10
75	50	32	25	90	11 17	0,11	0,13
75	63	32	25	90	11 17	0,10	0,14
90	63	32	28	95	11 17	0,18	0,20
90	75	32	28	95	11 17	0,14	0,20
110	75	40	28	95	11 17	0,22	0,25
110	90	40	30	95	11 17	0,22	0,27
125	90	40	30	95	11 17	0,33	0,33
125	110	40	30	95	11 17	0,27	0,37
140	110	50	20	95	11 17	0,42	0,54
140	125	50	20	95	11 17	0,38	0,52
160	110	50	20	95	11 17	0,65	0,72
160	125	50	20	95	11 17	0,55	0,71
160	140	50	20	95	11 17	0,42	0,68
180	125	50	20	95	17	0,72	
180	140	50	20	95	11 17	0,68	0,87
180	160	50	20	95	11 17	0,61	0,84
200	140	50	20	95	17	0,88	
200	160	50	20	95	11 17	0,82	1,07
200	180	50	20	95	11 17	0,75	1,04
225	200	50	20	95	11 17	0,95	1,30
250	200	50	20	110	11 17	1,21	1,61
250	225	60	25	110	11 17	1,33	1,84
280	225	60	30	120	17	1,93	
280	250	60	30	120	11 17	1,81	2,50
315	225	65	30	120	17	2,52	
315	250	65	30	120	11 17	2,46	3,24
315	280	65	30	120	11 17	2,31	3,18
355	280	70	30	120	11 17	3,08	4,15
355	315	70	30	120	11 17	2,95	4,06
400	315	70	30	140	11 17	3,62	4,39
400	355	70	35	140	11 17	3,76	5,53
450	355	70	30	140	11 17	5,60	7,62
450	400	70	35	140	11 17	4,76	7,08
500	355	70	35	140	11 17	7,26	9,63
500	400	70	35	140	11 17	6,56	8,93
500	450	70	35	140	11 17	5,93	8,76
560	400	70	35	140	11 17	9,18	12,20
560	450	70	35	140	11 17	8,66	11,85
560	500	70	35	140	11 17	7,58	11,14
630	500	70	50	160	11 17	11,73	16,08
630	560	70	40	160	11 17	11,09	16,48
710	560	80	50	200	11 17	19,18	26,29
710	630	80	50	200	11 17	18,34	25,58
800	710	80	50	200	11 17	23,37	32,59
900	800	120	50	220	11 17	34,49	48,23
1000	900	120	50	220	11 17	43,18	57,94

Ongoing engineering design efforts may affect the technical information listed in our publications.
Other SDR's available on request.

ELONGATED CONCENTRIC REDUCERS



PIPESTAR
AFRICA

ELONGATED CONCENTRIC REDUCERS

d1	d2	le1	le2	z1	SDR	Weight SDR17	Weight SDR11
mm	mm	mm	mm	mm		kg	kg
63	50	64	58	152	11 17	0,09	0,13
75	50	70	55	155	11 17	0,12	0,18
75	63	70	65	171	11 17	0,15	0,22
90	63	79	70	182	11 17	0,21	0,31
90	75	79	70	182	11 17	0,23	0,33
110	75	84	74	185	11 17	0,31	0,45
110	90	84	81	186	11 17	0,34	0,50
125	90	91	90	200	11 17	0,45	0,66
125	110	90	90	200	11 17	0,50	0,73
140	110	116	90	230	11 17	0,68	0,99
140	125	117	96	235	11 17	0,74	1,10
160	110	110	89	254	11 17	0,92	1,33
160	125	110	95	254	11 17	0,96	1,42
160	140	110	106	254	11 17	0,91	1,51
180	125	105	87	245	17	1,11	
180	140	115	90	260	11 17	1,25	2,27
180	160	126	125	279	11 17	1,44	2,12
200	140	123	114	279	17	1,55	
200	160	122	122	277	11 17	1,64	2,42
200	180	126	120	279	11 17	1,80	2,65
225	200	126	120	272	11 17	2,21	3,25
250	200	151	116	324	11 17	3,06	4,51
250	225	155	122	330	11 17	3,34	4,93
280	225	142	122	335	17	3,96	
280	250	139	135	340	11 17	4,25	6,63
315	225	150	125	365	17	5,29	
315	250	150	134	365	11 17	5,49	7,93
315	280	150	145	365	11 17	5,84	8,49
355	280	170	170	380	11 17	8,98	11,97
355	315	170	170	380	11 17	7,68	9,35
400	315	180	170	390	11 17	11,94	15,88
400	355	180	170	390	11 17	10,04	14,77
450	355	190	170	400	11 17	15,97	21,20
450	400	190	180	410	11 17	13,38	19,71
500	355	200	170	410	11 17	21,51	28,55
500	400	200	180	420	11 17	20,64	27,53
500	450	200	190	430	11 17	17,50	25,76
560	400	210	180	430	11 17	28,30	36,36
560	450	210	190	440	11 17	27,15	36,25
560	500	210	200	450	11 17	22,91	33,69
630	500	230	200	470	11 17	36,93	48,85
630	560	230	210	480	11 17	34,95	48,42
710	560	250	210	500	11 17	51,18	67,48
710	630	250	230	520	11 17	48,30	66,86

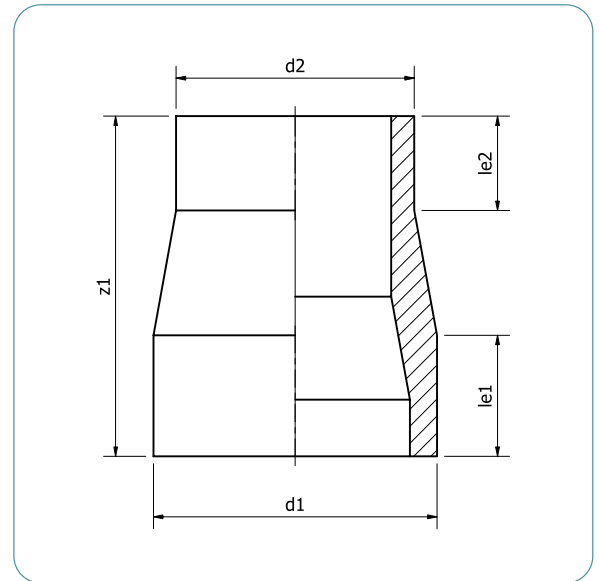

Ongoing engineering design efforts may affect the technical information listed in our publications.
Other SDR's available on request.



MOULDED TEES

EQUAL TEES

Specifications	L	A	B	H	Weight		
					mm	mm	mm
ØD1xØD2xØD1	mm	mm	mm	mm	SDR17	SDR11	SDR9
50x50x50	170	55	55	82	0,17	0,17	
63x63x63	200	63	63	104	0,21	0,33	0,48
75x75x75	230	70	70	114	0,39	0,53	0,79
90x90x90	260	79	79	133	0,59	0,81	1,21
110x110x110	290	82	82	145	0,96	1,27	1,85
125x125x125	315	87	87	160	1,42	1,86	
140x140x140	345	92	92	170	1,92	2,59	
160x160x160	325	75	75	170	2,04	2,84	4,25
180x180x180	420	105	105	225	3,99	5,46	
200x200x200	377	75	84	200	3,99	5,48	8,19
225x225x225	484	120	120	230	5,82	7,77	
250x250x250	517	120	120	265	9,10	11,61	
280x280x280	590	140	140	300	12,26	16,96	
315x315x315	615	130	125	310	15,36	21,89	
355x355x355	630	120	120	350	23,27	32,80	
400x400x400	670	120	120	360	29,85	39,07	
450x450x450	805	150	175	430	43,50	56,27	
500x500x500	855	150	180	485	57,00	72,64	
560x560x560	910	145	180	525	68,00	96,00	
630x630x630	990	145	180	530	93,00	135,50	
710x710x710	1140	150	190	565	118,00	167,00	
800x800x800	1260	150	190	610	163,00	228,00	
900x900x900	1378	200	210	710	132,00		
1000x1000x1000	1448	200	210	760	148,00		
1200x1200x1200	1690	200	210	860	156,00		

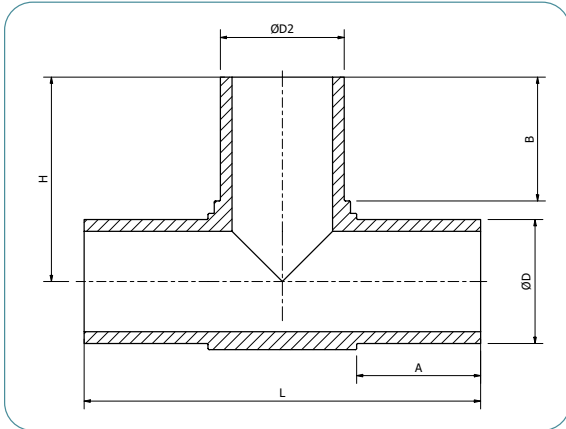

REDUCING TEES

Specifications	L	A	B	H	Weight	
					mm	mm
ØD1xØD2xØD1	mm	mm	mm	mm	SDR17	SDR11
63x50x63	190	63	55	96		0,26
75x50x75	205	70	55	100		0,44
75x63x75	225	70	63	107		0,47
90x50x90	230	79	55	110		0,60
90x63x90	245	79	63	118		0,67
90x75x90	252	79	70	126		0,73
110x50x110	252	79	70	126		0,86
110x63x110	250	82	63	118		0,88
110x75x110	264	82	70	137		1,01
110x90x110	275	82	79	135	0,82	1,14
160x90x160	300	98	79	175	1,70	2,44
160x110x160	325	98	82	175	1,89	2,64
200x90x200	330	112	70	183	3,08	4,06
200x110x200	355	112	82	196	3,22	4,33
200x160x200	420	112	98	207	4,04	5,49
250x90x250	395	129	79	218	3,08	4,06
250x110x250	395	129	82	216	5,34	7,41
250x160x250	398	95	81	218	5,54	7,54
250x200x250	379	75	112	254	5,71	8,21
315x160x315	450	130	77	247	10,21	12,72
315x200x315	455	110	95	285	10,45	13,46
315x250x315	460	80	80	248	10,90	13,61

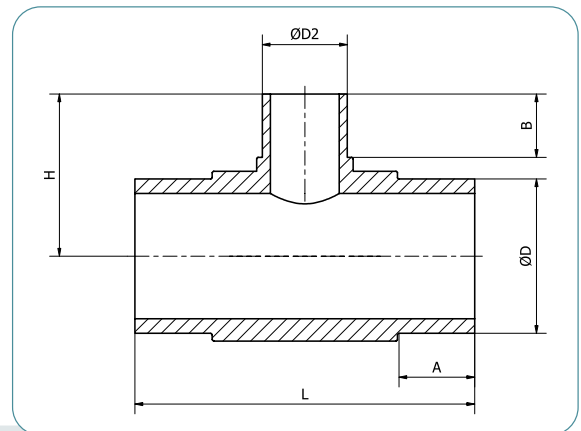

Ongoing engineering design efforts may affect the technical information listed in our publications.

MOULDED ELBOWS



PIPESTAR
AFRICA

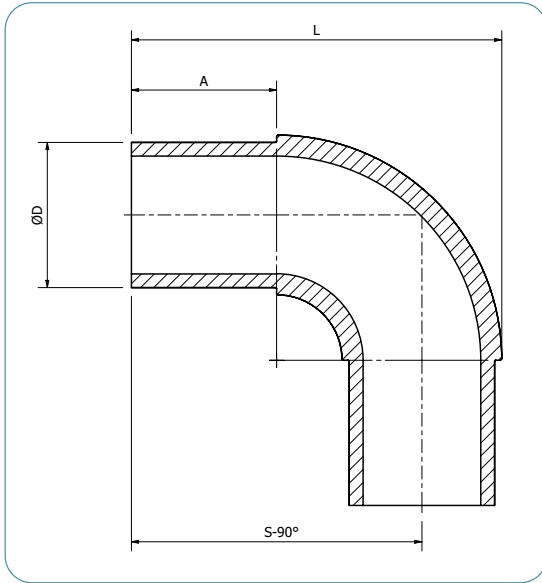

90° ELBOW

Specifications	L	A	S-90°	Weight		
				SDR17	SDR11	SDR9
ØDx90°	mm	mm	mm			
50x90°	120	66	95	0,13	0,13	
63x90°	133	63	102	0,19	0,25	0,36
75x90°	165	70	126	0,33	0,43	0,63
90x90°	182	79	137	0,47	0,64	0,93
110x90°	214	82	159	0,81	1,03	1,53
125x90°	242	87	178	1,37	1,74	
140x90°	244	88	174	1,33	1,74	
160x90°	260	85	178	2,03	2,67	3,54
180x90°	297	97	207	2,61	3,47	
200x90°	308	97	208	3,41	4,43	6,59
225x90°	367	115	255	5,09	7,13	
250x90°	362	100	237	5,62	7,66	
280x90°	433	130	293	8,53	11,94	
315x90°	460	125	303	8,63	15,36	
355x90°	540	150	363	20,91	25,44	
400x90°	600	180	400	27,33	35,40	
450x90°	665	160	425	35,00	47,37	
500x90°	704	160	450	45,00	62,00	
560x90°	784	160	504	62,50	79,50	
630x90°	860	170	535	89,50	111,00	
710x90°	900	170	545	90,20	124,00	
800x90°	990	170	590	101,32	132,56	
900x90°	1120	200	670	115,68		
1000x90°	1220	200	720	137,59		
1200x90°	1420	200	820	142,76		

45° ELBOW

Specifications	L	A	S-45°	Weight		
				SDR17	SDR11	SDR9
ØDx45°	mm	mm	mm			
50x45°	155	60	70	0,12	0,12	
63x45°	160	63	79	0,14	0,19	0,27
75x45°	180	70	89	0,19	0,27	0,39
90x45°	228	79	114	0,39	0,52	0,77
110x45°	246	82	118	0,57	0,79	1,18
125x45°	248	87	115	0,71	0,99	
160x45°	310	98	138	1,52	2,03	2,99
180x45°	340	100	159	2,04	2,77	
200x45°	355	112	167	2,89	3,86	5,79
225x45°	398	120	173	3,44	4,95	
250x45°	420	129	192	4,70	6,34	
280x45°	465	140	215	5,30	6,65	
315x45°	490	150	220	8,59	11,94	
355x45°	530	145	240	13,35	17,05	
400x45°	610	160	272	18,35	24,40	
450x45°	660	170	285	23,99	33,50	
500x45°	735	170	315	30,85	42,62	
560 x45°	760	170	325	40,00	56,00	
630x45°	820	170	330	52,00	73,50	
710x45°	830	170	350	63,00	88,00	
800x45°	900	170	350	88,00	100,00	
900x45°	1020	200	460	93,00		
1000x45°	1100	200	510	106,58		
1200x45°	1250	200	490	112,53		
1200x45°	1250	200	490	112,53		

Ongoing engineering design efforts may affect the technical information listed in our publications.

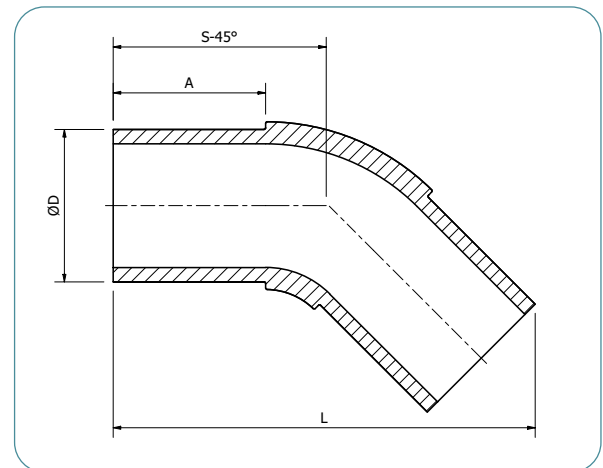

Ongoing engineering design efforts may affect the technical information listed in our publications.

ELECTROFUSION COUPLING

STRAIGHT COUPLING

Specifications	L	A	Ød	Weight SDR11
ØD	mm	mm	mm	kg
20	85	40	4,70	0,05
25	90	43	4,70	0,06
32	90	44	4,70	0,09
40	95	45	4,70	0,11
50	105	50	4,70	0,16
63	110	50	4,70	0,25
75	135	65	4,70	0,34
90	130	63	4,70	0,50
110	150	70	4,70	0,79
125	165	80	4,70	1,02
140	170	80	4,70	1,18
160	180	85	4,70	1,63
180	210	100	4,70	2,11
200	205	100	4,70	2,82
225	220	105	4,70	3,32
250	215	105	4,70	4,02
280	226	109	4,70	5,48
315	225	110	4,70	6,30
355	265	130	4,70	9,24
400	310	150	4,70	13,59
450	328	160	4,70	17,74
500	370	180	4,70	25,00
560	380	185	4,70	32,00
630	430	215	4,70	41,50

Ongoing engineering design efforts may affect the technical information listed in our publications.

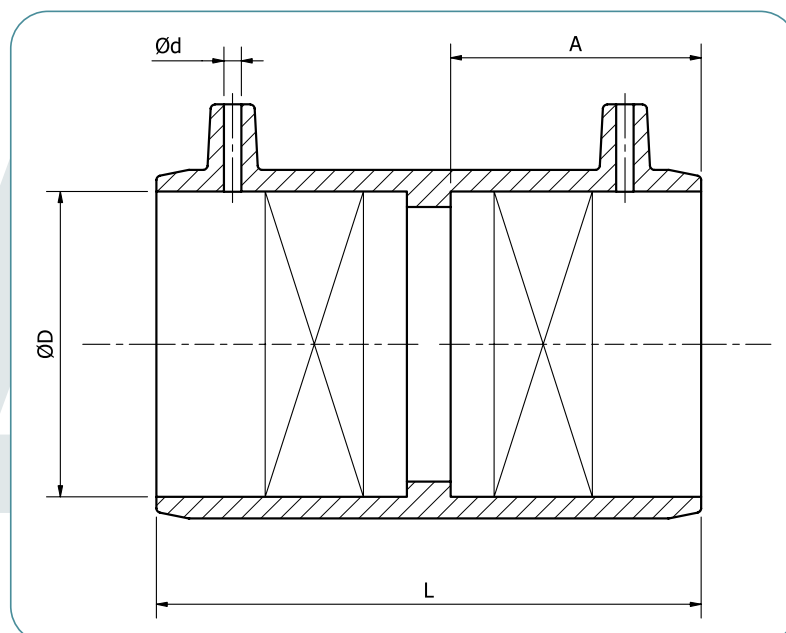

FLANGES

Carbon steel hot dipped galvanised



PIPESTAR
AFRICA

FLANGE DIMENSIONS									FASTENERS				
FLANGE SIZE	OD	ID	THICK-NESS	PCD	NO. OF HOLES	HOLE Ø	CHAMFER ANGLE	KG/PC	PSA RECOMMENDATION				
									D2	P-P* HEX BOLT	P-S** HEX BOLT	P-P* STUD BOLT	P-S** STUD BOLT
BS T/D													
25mm	101,6	38	10	73	4	14,3	4	0,50	M12	65	55	85	70
32mm	114,3	45	10	82,6	4	14,3	4	0,63	M12	65	55	85	70
40mm	120,7	51	10	87,3	4	14,3	4	0,69	M12	65	55	85	70
50mm	133,4	63	10	98,4	4	14,3	4	0,80	M12	65	55	85	70
63mm	152,4	78	10	114,3	4	17,5	4	0,98	M16	70	60	95	80
75mm	165,1	92	10	127	4	17,5	4	1,09	M16	70	60	95	80
90mm	184,1	110	10	146	4	17,5	4	1,27	M16	90	65	110	90
110mm	215,9	136	10	177,8	4	17,5	4	1,66	M16	100	75	125	95
125mm	215,9	136	10	177,8	4	17,5	4	1,66	M16	100	75	125	95
140mm	254	158	12	209,6	8	17,5	6	2,75	M16	110	75	125	100
160mm	279,4	190	12	235	8	17,5	6	2,93	M16	120	85	145	110
180mm	279,4	190	12	235	8	17,5	6	2,93	M16	120	85	145	110
200mm	336,3	237	12	292,1	8	17,5	6	4,04	M16	120	85	145	110
225mm	336,3	237	12	292,1	8	17,5	6	4,04	M16	140	95	165	120
250mm	406,4	279	16	355,6	8	22,2	8	8,23	M20	160	110	180	140
280mm	406,4	292	16	355,6	8	22,2	8	7,51	M20	160	110	180	140
315mm	457,2	330	19	406,4	12	22,2	8	11,10	M20	180	130	210	150
355mm	527,1	376	22	469,9	12	25,4	8	17,50	M24	200	140	240	180
400mm	577,9	430	22	520,7	12	25,4	8	19,20	M24	210	150	250	180
450mm	641,4	476	25	584,2	12	25,4	8	27,30	M24	220	150	250	190
500mm	704,9	533	28	641,4	16	25,4	8	35,00	M24	240	170	270	200
560mm	762	592	28	698	16	28,6	8	37,50	M24	240	170	270	200
630mm	825,5	662	30	755,7	16	28,6	8	46,80	M24	240	170	270	200

Ongoing engineering design efforts may affect the technical information listed in our publications. *P-P: Plastic to Plastic **P-S: Plastic to Steel

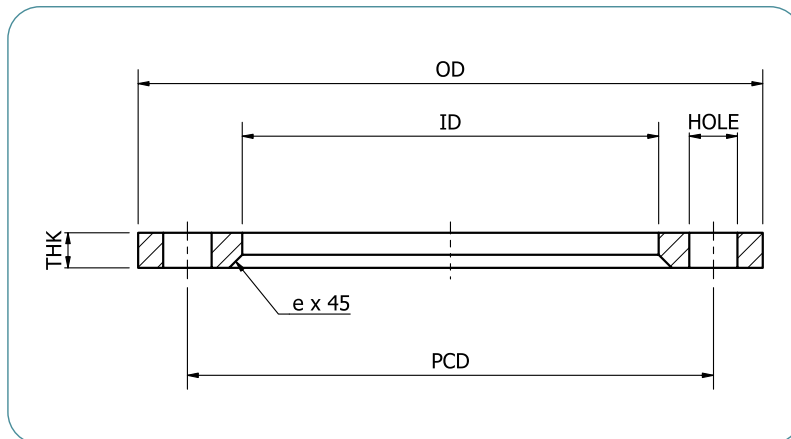



FLANGE DIMENSIONS									FASTENERS				
FLANGE SIZE	OD	ID	THICK-NESS	PCD	NO. OF HOLES	HOLE Ø	CHAMFER ANGLE	KG/PC	PSA RECOMMENDATION				
									D2	P-P* HEX BOLT	P-S** HEX BOLT	P-P* STUD BOLT	P-S** STUD BOLT
SANS 1123 - T1000													
50mm	150	63	10	110	4	18	4	1,07	M16	70	60	95	80
63mm	165	78	10	125	4	18	4	1,23	M16	70	60	95	80
75mm	185	92	12	145	4	18	4	1,82	M16	75	65	100	85
90mm	200	110	12	160	8	18	4	1,88	M16	90	70	115	95
110mm	220	136	12	180	8	18	4	2,03	M16	110	75	125	100
125mm	220	136	12	180	8	18	4	2,03	M16	110	75	125	100
140mm	250	158	14	210	8	18	6	3,02	M16	110	80	130	105
160mm	285	190	16	240	8	22	6	4,08	M20	140	100	160	130
180mm	285	190	16	240	8	22	6	4,08	M20	140	100	160	130
200mm	340	237	18	295	8	22	6	6,17	M20	140	100	170	130
225mm	340	237	18	295	8	22	6	6,17	M20	160	110	190	140
250mm	395	279	20	350	12	22	8	8,93	M20	160	120	190	150
280mm	395	292	20	350	12	22	8	8,02	M20	160	120	190	150
315mm	445	330	22	400	12	22	8	11,30	M20	190	130	210	160
355mm	505	376	25	460	16	22	8	16,40	M20	200	140	230	170
400mm	565	430	25	515	16	26	8	19,10	M24	220	150	250	190
450mm	615	476	30	565	20	26	8	25,60	M24	230	160	260	200
500mm	670	533	30	620	20	26	8	28,10	M24	240	170	270	200
560mm	730	592	35	675	20	26	8	36,50	M24	250	180	280	210
630mm - 725 PCD	780	662	36	725	20	26	8	39,80	M24	250	180	280	210
630mm - 780 PCD	835	662	36	780	20	26	8	54,60	M24	250	180	280	210
710mm	895	737	40	840	24	26	8	59,70	M24	260	190	290	220
800mm	1015	840	45	950	24	33	8	82,90	M30	280	210	320	250
900mm	1115	942	50	1050	28	33	8	100,40	M30	290	220	330	260
1000mm	1230	1045	55	1160	28	33	8	132,50	M30	300	230	340	270
SANS 1123 - T1600													
25mm	105	38	10	75	4	14	4	0,55	M12	65	55	85	70
32mm	115	45	10	85	4	14	4	0,65	M12	65	55	85	70
40mm	140	51	10	100	4	18	4	0,97	M16	70	60	95	80
50mm	150	63	10	110	4	18	4	1,07	M16	70	60	95	80
63mm	165	78	12	125	4	18	4	1,47	M16	75	60	95	85
75mm	185	92	12	145	4	18	4	1,82	M16	80	65	100	85
90mm	200	110	14	160	8	18	4	2,19	M16	100	75	115	95
110mm	220	136	14	180	8	18	4	2,36	M16	110	80	130	105
125mm	220	136	14	180	8	18	4	2,36	M16	110	80	130	105
140mm	250	158	16	210	8	18	6	3,45	M16	110	85	135	110
160mm	285	190	18	240	8	22	6	4,59	M20	140	100	170	130
180mm	285	190	18	240	8	22	6	4,59	M20	140	100	170	130
200mm	340	237	22	295	12	22	6	7,28	M20	150	110	170	140
225mm	340	237	22	295	12	22	6	7,28	M20	170	120	190	150
250mm	405	279	25	355	12	26	8	12,05	M24	180	130	210	170
280mm	405	292	25	355	12	26	8	10,90	M24	180	130	210	170
315mm	460	330	28	410	12	26	8	16,40	M24	200	150	240	180
355mm	520	376	30	470	16	26	8	21,90	M24	220	160	250	190
400mm	580	430	32	525	16	26	8	27,80	M24	230	170	270	200
450mm	640	476	35	585	20	26	8	36,60	M24	240	170	270	210
500mm	715	533	40	650	20	33	8	50,70	M30	270	200	310	240
560mm	775	592	40	710	20	33	8	56,40	M30	270	200	310	240
630mm	840	662	50	770	20	33	8	82,70	M30	290	220	330	260
710mm	910	737	50	840	24	33	8	79,90	M30	290	220	330	260
800mm	1025	840	60	950	24	39	8	114,30	M36	310	240	360	290
900mm	1125	942	65	1050	28	39	8	134,70	M36	320	250	370	300
1000mm	1255	1045	70	1170	28	39	8	190,30	M36	330	260	380	310

Ongoing engineering design efforts may affect the technical information listed in our publications.

*P-P: Plastic to Plastic **P-S: Plastic to Steel

FLANGES



PIPESTAR
AFRICA

Carbon steel hot dipped galvanised

FLANGE DIMENSIONS									FASTENERS				
FLANGE SIZE	OD	ID	THICK-NESS	PCD	NO. OF HOLES	HOLE Ø	CHAMFER ANGLE	KG/PC	PSA RECOMMENDATION				
									D2	P-P* HEX BOLT	P-S** HEX BOLT	P-P* STUD BOLT	P-S** STUD BOLT
SANS 1123 - T2500													
90mm	200	103	22	160	8	18	4	3,64	M16	110	90	135	115
110mm	235	136	25	190	8	22	4	5,07	M20	140	110	160	140
125mm	235	136	25	190	8	22	4	5,07	M20	140	110	160	140
140mm	270	158	28	220	8	26	4	7,35	M24	150	120	180	150
160mm	300	190	30	250	8	26	6	8,98	M24	170	130	200	170
180mm	300	190	30	250	8	26	6	8,98	M24	170	130	200	170
200mm	360	237	28	310	12	26	6	11,30	M24	160	130	200	160
225mm	360	237	28	310	12	26	6	11,30	M24	180	140	220	170
250mm	425	279	30	370	12	26	8	17,60	M24	190	140	220	180
280mm	425	292	30	370	12	26	8	16,20	M24	190	140	220	180
315mm	485	330	32	430	16	26	8	22,80	M24	210	160	250	190
355mm	555	376	35	490	16	33	8	32,30	M30	240	180	270	210
400mm	620	430	40	550	16	33	8	45,00	M30	260	190	290	230
450mm	670	476	45	600	20	33	8	55,70	M30	270	200	300	240
500mm	730	533	50	660	20	33	8	70,10	M30	290	220	330	260
560mm	785	594	55	710	20	39	8	79,10	M36	300	230	350	280
ASA 150#													
32mm	107,9	45	10	79,4	4	15,9	4	0,53	M12	65	55	85	70
40mm	117,5	51	10	88,9	4	15,9	4	0,63	M12	65	55	85	70
50mm	127	63	10	98,4	4	15,9	4	0,69	M12	70	60	95	80
63mm	152,4	78	12	120,6	4	19	4	1,16	M16	75	60	95	85
75mm	177,8	92	12	139,7	4	19	4	1,61	M16	75	65	100	85
90mm	190,5	103	12	152,4	4	19	4	1,80	M16	90	70	115	95
110mm	228,6	136	15	190,5	8	19	4	2,86	M16	110	90	135	105
125mm	228,6	136	15	190,5	8	19	4	2,86	M16	110	90	135	105
140mm	254	158	16	215,9	8	22,2	6	3,52	M20	120	90	150	120
160mm	279,4	190	20	241,3	8	22,2	6	4,69	M20	140	110	170	140
180mm	279,4	190	20	241,3	8	22,2	6	4,69	M20	140	110	170	140
200mm	342,9	237	20	298,4	8	22,2	6	7,10	M20	140	110	170	140
225mm	342,9	237	20	298,4	8	22,2	6	7,10	M20	160	120	190	150
250mm	406,4	279	25	361,9	12	25,4	8	12,30	M24	180	130	210	170
280mm	406,4	292	25	361,9	12	25,4	8	11,20	M24	180	130	210	170
315mm	482,6	330	28	431,8	12	25,4	8	20,10	M24	200	150	240	180
355mm	533,4	376	30	476,2	12	28,6	8	24,70	M24	220	160	250	190
400mm	596,9	430	30	539,8	16	28,6	8	29,30	M24	230	160	260	200
450mm	635	476	35	577,8	16	31,9	8	34,70	M30	250	180	280	220
500mm	698,5	533	38	635	20	31,9	8	43,10	M30	260	190	300	230
560mm	812,8	592	40	749,3	20	34,9	8	70,60	M33	270	200	310	240
630mm	812,8	662	40	749,3	20	34,9	8	54,40	M33	270	200	310	240
710mm	927,1	737	52,4	863,6	28	34,9	8	122,00	M33	300	230	340	270
800mm	1060,4	840	57,1	977,9	28	41,3	8	170,00	M39	310	240	360	290
900mm	1168,4	942	60,3	1085,8	32	41,3	8	211,00	M39	320	250	370	300
1000mm	1289	1045	63,5	1200,1	36	41,3	8	279,90	M39	320	250	370	300

Ongoing engineering design efforts may affect the technical information listed in our publications.

*P-P: Plastic to Plastic **P-S: Plastic to Steel



FLANGE DIMENSIONS									FASTENERS				
FLANGE SIZE	OD	ID	THICK-NESS	PCD	NO. OF HOLES	HOLE Ø	CHAMFER ANGLE	KG/PC	PSA RECOMMENDATION				
									D2	P-P* HEX BOLT	P-S** HEX BOLT	P-P* STUD BOLT	P-S** STUD BOLT
SANS 1123 - T1000 BLANK													
63mm	165		12	125	4	18		1,92	M16		60		90
75mm	185		12	145	4	18		2,44	M16		70		90
90mm	200		14	160	8	18		3,23	M16		80		100
110mm	225		14	180	8	18		3,96	M16		80		110
125mm	225		14	180	8	18		3,96	M16		80		110
140mm	250		16	210	8	18		5,92	M16		90		110
160mm	285		18	240	8	22		8,59	M20		100		130
180mm	285		18	240	8	22		8,59	M20		100		130
200mm	340		18	295	8	22		12,41	M20		100		130
225mm	340		18	295	8	22		12,41	M20		110		140
250mm	395		20	350	12	22		18,60	M20		120		150
280mm	395		20	350	12	22		18,60	M20		120		150
315mm	445		22	400	12	22		26,10	M20		130		160
355mm	505		25	460	16	22		38,20	M20		140		170
400mm	565		25	515	16	26		47,60	M24		150		190
450mm	615		30	565	20	26		67,50	M24		160		200
500mm	670		32	620	20	26		86,00	M24		170		210
560mm	730		35	675	20	26		112,20	M24		180		210
630mm - 725	780		38	725	20	26		139,50	M24		190		220
630mm - 780	835		38	780	20	26		160,30	M24		190		220
SANS 1123 - T1600 BLANK													
50mm	150		10	110	4	18		1,31	M16		60		80
63mm	165		12	125	4	18		1,92	M16		60		90
75mm	185		12	145	4	18		2,44	M16		70		90
90mm	200		14	160	8	18		3,23	M16		80		100
110mm	220		14	180	8	18		3,60	M16		80		110
125mm	220		14	180	8	18		3,60	M16		80		110
140mm	250		16	210	8	18		5,92	M16		90		110
160mm	285		18	240	8	22		8,60	M20		100		130
180mm	285		18	240	8	22		8,60	M20		100		130
200mm	340		22	295	12	22		14,90	M20		110		140
225mm	340		22	295	12	22		14,90	M20		120		150
250mm	405		25	355	12	26		24,10	M24		130		170
280mm	405		25	355	12	26		24,10	M24		130		170
315mm	460		28	410	12	26		35,20	M24		150		180
355mm	520		30	470	16	26		48,10	M24		160		190
400mm	580		35	525	16	26		70,40	M24		170		210
450mm	640		40	585	20	26		97,80	M24		180		220
500mm	715		40	650	20	33		120,80	M30		200		240
560mm	775		40	710	20	33		142,90	M30		200		240
630mm	840		50	770	20	33		211,00	M30		220		260

Ongoing engineering design efforts may affect the technical information listed in our publications.

*P-P: Plastic to Plastic **P-S: Plastic to Steel

FASTENERS



PIPESTAR
AFRICA

Carbon steel hot dipped galvanised

HEX BOLT DIN931

SIZE	d	b	da	K	L	S	Weight/pc
M12							
M12 x 65mm	11.7-11.96	30	11.73-12	7.32-7.68	64.4-65.6	18.67-19	0,07
M12 x 75mm	11.7-11.96	30	11.73-12	7.32-7.68	74.4-75.6	18.67-19	0,08
M16							
M16 x 60mm	15.68-15.96	38	15.73-16	9.82-10.18	59.4-60.6	23.67-24	0,13
M16 x 65mm	15.68-15.96	38	15.73-16	9.82-10.18	64.4-65.6	23.67-24	0,14
M16 x 70mm	15.68-15.96	38	15.73-16	9.82-10.18	69.4-70.6	23.67-24	0,15
M16 x 75mm	15.68-15.96	38	15.73-16	9.82-10.18	74.4-75.6	23.67-24	0,16
M16 x 80mm	15.68-15.96	38	15.73-16	9.82-10.18	79.4-80.6	23.67-24	0,16
M16 x 85mm	15.68-15.96	38	15.73-16	9.82-10.18	84.4-85.6	23.67-24	0,17
M16 x 90mm	15.68-15.96	38	15.73-16	9.82-10.18	89.3-90.7	23.67-24	0,17
M16 x 100mm	15.68-15.96	38	15.73-16	9.82-10.18	99.3-100.7	23.67-24	0,19
M16 x 110mm	15.68-15.96	38	15.73-16	9.82-10.18	109.3-110.7	23.67-24	0,20
M16 x 120mm	15.68-15.96	38	15.73-16	9.82-10.18	119.3-120.7	23.67-24	0,22
M16 x 130mm	15.68-15.96	44	15.73-16	9.82-10.18	129.2-130.8	23.67-24	0,24
M16 x 140mm	15.68-15.96	44	15.73-16	9.82-10.18	139.2-140.8	23.67-24	0,26
M16 x 150mm	15.68-15.96	44	15.73-16	9.82-10.18	149.2-150.8	23.67-24	0,30
M20							
M20 x 110mm	19.62-19.96	46	19.67-20	12.28-12.72	109.3-110.7	29.67-30	0,21
M20 x 120mm	19.62-19.96	46	19.67-20	12.28-12.72	119.3-120.7	29.67-30	0,22
M20 x 130mm	19.62-19.96	52	19.67-20	12.28-12.72	129.2-130.8	29.67-30	0,37
M20 x 140mm	19.62-19.96	52	19.67-20	12.28-12.72	139.2-140.8	29.67-30	0,40
M20 x 150mm	19.62-19.96	52	19.67-20	12.28-12.72	149.2-150.8	29.67-30	0,42
M20 x 160mm	19.62-19.96	52	19.67-20	12.28-12.72	159.2-160.8	29.67-30	0,45
M20 x 170mm	19.62-19.96	52	19.67-20	12.28-12.72	159.2-170.8	29.67-30	0,47
M20 x 180mm	19.62-19.96	52	19.67-20	12.28-12.72	179.2-180.8	29.67-30	0,49
M20 x 190mm	19.62-19.96	52	19.67-20	12.28-12.72	189.08-190.92	29.67-30	0,52
M20 x 200mm	19.62-19.96	52	19.67-20	12.28-12.72	199.08-200.92	29.67-30	0,55
M20 x 220mm	19.62-19.96	52	19.67-20	12.28-12.72	219.08-220.92	29.67-30	0,60
M20 x 240mm	19.62-19.96	52	19.67-20	12.28-12.72	239.08-240.92	29.67-30	0,62
M20 x 260mm	19.62-19.96	52	19.67-20	12.28-12.72	259.08-260.92	29.67-30	0,69
M24							
M24 x 150mm	23.58-23.95	60	23.67-24	14.78-15.22	149.2-150.8	35-36	0,65
M24 x 160mm	23.58-23.95	60	23.67-24	14.78-15.22	158-162	35-36	0,68
M24 x 170mm	23.58-23.95	60	23.67-24	14.78-15.22	168-172	35-36	0,70
M24 x 180mm	23.58-23.95	60	23.67-24	14.78-15.22	178-182	35-36	0,75
M24 x 190mm	23.58-23.95	60	23.67-24	14.78-15.22	187.7-192.3	35-36	0,77
M24 x 200mm	23.58-23.95	60	23.67-24	14.78-15.22	197.7-202.3	35-36	0,81
M24 x 210mm	23.58-23.95	73	23.67-24	14.78-15.22	207.7-212.3	35-36	0,84
M24 x 220mm	23.58-23.95	73	23.67-24	14.78-15.22	217.7-222.3	35-36	0,87
M24 x 230mm	23.58-23.95	73	23.67-24	14.78-15.22	227.7-232.3	35-36	0,91
M24 x 240mm	23.58-23.95	73	23.67-24	14.78-15.22	237.7-242.3	35-36	0,94
M24 x 250mm	23.58-23.95	73	23.67-24	14.78-15.22	247.7-252.3	35-36	0,97
M24 x 260mm	23.58-23.95	73	23.67-24	14.78-15.22	257.4-262.6	35-36	1,00
M24 x 270mm	23.58-23.95	73	23.67-24	14.78-15.22	267.4-272.6	35-36	1,04
M24 x 280mm	23.58-23.95	73	23.67-24	14.78-15.22	277.4-282.6	35-36	1,07
M24 x 300mm	23.58-23.95	73	23.67-24	14.78-15.22	297.4-302.6	35-36	1,20
M30							
M30 x 220mm	29.52-29.95	85	29.48-30	18.28-19.12	217.7-222.3	45-46	1,38
M30 x 230mm	29.52-29.95	85	29.48-30	18.28-19.12	227.7-232.3	45-46	1,56
M30 x 240mm	29.52-29.95	85	29.48-30	18.28-19.12	237.7-242.3	45-46	1,58
M30 x 250mm	29.52-29.95	85	29.48-30	18.28-19.12	247.3-252.3	45-46	1,59
M30 x 260mm	29.52-29.95	85	29.48-30	18.28-19.12	257.4-262.6	45-46	1,64
M30 x 270mm	29.52-29.95	85	29.48-30	18.28-19.12	267.4-272.6	45-46	1,70
M30 x 280mm	29.52-29.95	85	29.48-30	18.28-19.12	277.4-282.6	45-46	1,75
M30 x 290mm	29.52-29.95	85	29.48-30	18.28-19.12	287.4-292.6	45-46	1,81
M30 x 300mm	29.52-29.95	85	29.48-30	18.28-19.12	297.4-302.6	45-46	1,86
M36							
M36 x 270mm	35.46-35.94	97	35.38-36	22.08-22.92	267.4-272.6	53.8-55	2,51
M36 x 290mm	35.46-35.94	97	35.38-36	22.08-22.92	287.4-292.6	53.8-55	2,67
M36 x 310mm	35.46-35.94	97	35.38-36	22.08-22.92	307.4-312.6	53.8-55	2,83

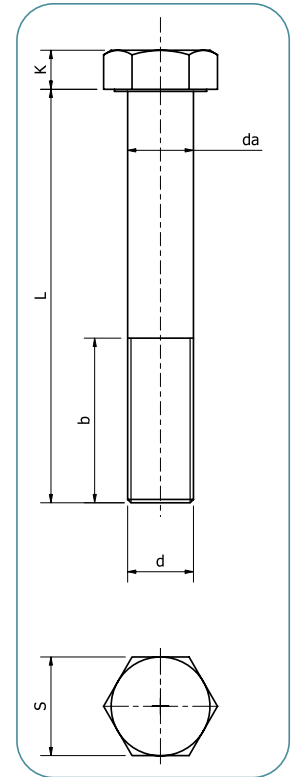

Ongoing engineering design efforts may affect the technical information listed in our publications.



HEX NUT DIN 934

d	S	K	e	Weight/pc
M12	Max 19	Max 10	Min 21.1	0,02
	Min 18.67	Min 9.64		
M16	Max 24	Max 13	Min 26.75	0,03
	Min 23.67	Min 12.3		
M20	Max 30	Max 16	Min 32.95	0,06
	Min 29.16	Min 14.9		
M24	Max 36	Max 19	Min 39.55	0,11
	Min 35	Min 17.7		
M30	Max 46	Max 24	Min 50.85	0,22
	Min 45	Min 22.7		
M36	Max 55	Max 29	Min 60.79	0,40
	Min 53.8	Min 27.4		

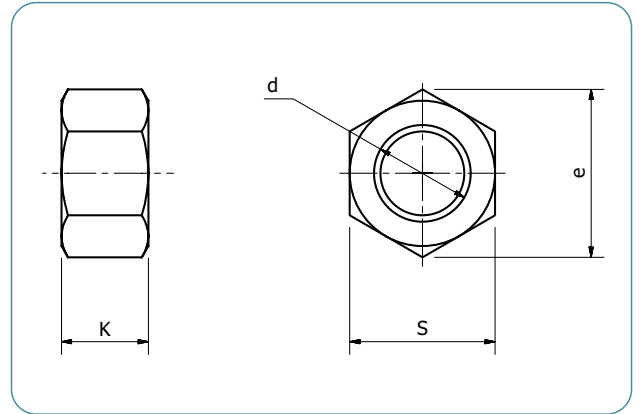

Ongoing engineering design efforts may affect the technical information listed in our publications.

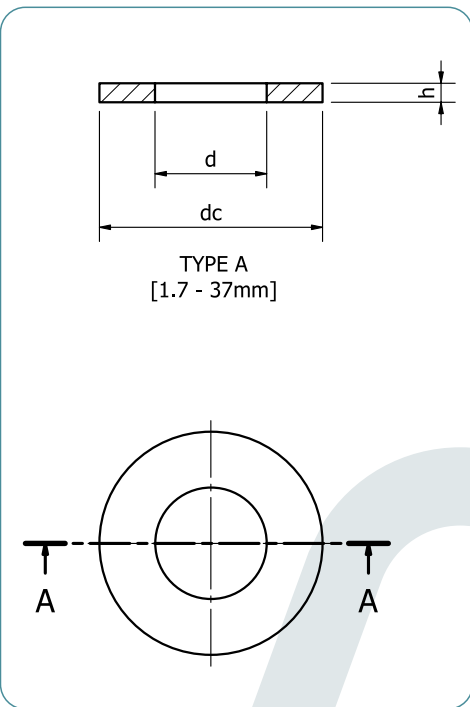

FLAT WASHERS DIN125A

SIZE	d	dc	h	Weight/pc
M12	Max 13.27	Max 24	Max 2.7	0,01
	Min 13	Min 23.48	Min 2.3	
M16	Max 17.27	Max 30	Max 3.3	0,01
	Min 17	Min 29.48	Min 2.7	
M20	Max 21.33	Max 37	Max 3.3	0,02
	Min 21	Min 36.38	Min 2.7	
M24	Max 25.33	Max 44	Max 4.3	0,03
	Min 25	Min 43.38	Min 3.7	
M30	Max 31.39	Max 56	Max 4.3	0,05
	Min 31	Min 55.28	Min 3.7	
M36	Max 37.62	Max 66	Max 5.6	0,09
	Min 37	Min 64.8	Min 4.4	

Ongoing engineering design efforts may affect the technical information listed in our publications.

THREADED ROD

Carbon steel hot dipped galvanised



PIPESTAR
AFRICA

THREADED ROD

SIZE	P	d	L	Weight/Rod
M12X1000	1,75	11.701-11.966	990-1010	0,73
M16X1000	2	15.682-15.962	990-1010	1,30
M20X1000	2,5	19.623-19.958	990-1010	2,08
M24X1000	3	23.577-23.952	990-1010	3,00
M30X1000	3,5	29.522-29.947	990-1010	4,75
M12X1500	1,75	11.701-11.966	1490-1510	1,09
M16X1500	2	15.682-15.962	1490-1510	2,00
M20X1500	2,5	19.623-19.958	1490-1510	3,12
M24X1500	3	23.577-23.952	1490-1510	4,50
M30X1500	3,5	29.522-29.947	1490-1510	7,13

Ongoing engineering design efforts may affect the technical information listed in our publications.

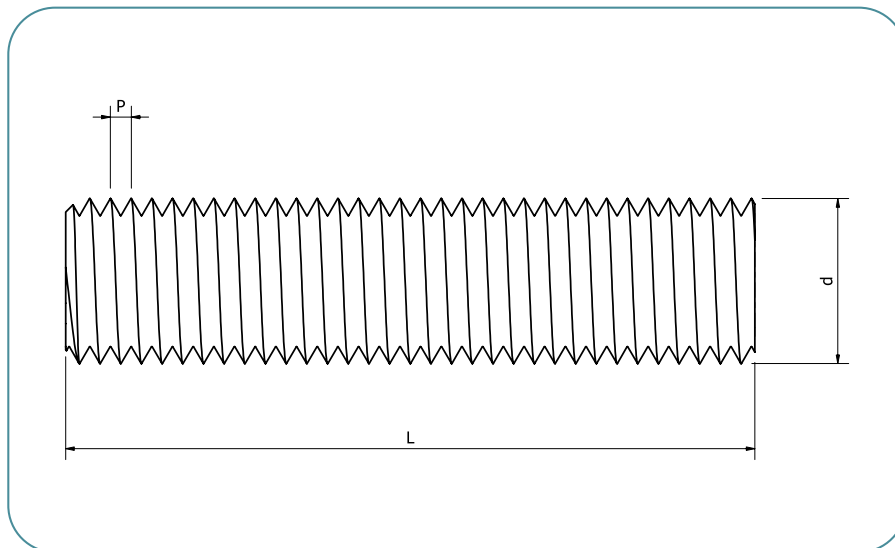



PE 100 HDPE PIPES

DIMENSIONS OF PE 100 HDPE PIPES ISO / SANS 4427-2:2008 - SDR 7.4 TO SDR 17

SDR RATING		SDR 7.4						SDR 9						SDR 11						SDR 13.6						SDR 17														
PE 80		20		25				16		20				12.5		16		10		12.5		10		8		10		10												
OD	min	max	min	max	min	max	NOM ID	MASS Kg/M	min	Avg	max	min	Avg	max	min	Avg	max	min	Avg	max	min	Avg	max	min	Avg	max	min	Avg	max	min	Avg	max	min	Avg	max					
16	16.3	2.3	2.5	2.7	11.15	0.10	11.85	0.09	2.0	2.15	2.3	2.3	2.15	2.3	15.9	0.12	2	2.15	2.3	2.15	2.3	2.15	2.3	2.15	2.3	2.15	2.3	2.15	2.3	2.15	2.3	2.15	2.3	2.15	2.3					
20	20.3	3	3.2	3.4	13.75	0.16	15.15	0.13	2.3	2.5	2.7	2.4	2.5	2.7	20.2	0.17	2.3	2.5	2.7	2.5	2.7	2.5	2.7	2.5	2.7	2.5	2.7	2.5	2.7	2.5	2.7	2.5	2.7	2.5	2.7					
25	25.3	3.5	3.75	4	17.7	0.24	18.8	0.21	3.0	3.2	3.4	3.0	3.2	3.4	25.8	0.28	3	3.2	3.4	3.2	3.4	3.2	3.4	3.2	3.4	3.2	3.4	3.2	3.4	3.2	3.4	3.2	3.4	3.2	3.4					
32	32.3	4.4	4.7	5	22.8	0.39	24.5	0.33	3.6	3.85	4.1	3.6	3.85	4.1	30.6	0.43	3.7	3.95	4.2	3.7	3.95	4.2	3.7	3.95	4.2	3.7	3.95	4.2	3.7	3.95	4.2	3.7	3.95	4.2	3.7	3.95				
40	40.3	5.5	5.95	6.2	28.5	0.60	30.6	0.51	4.5	4.8	5.1	4.5	4.8	5.1	40.4	0.67	4.6	4.9	5.2	4.6	4.9	5.2	4.6	4.9	5.2	4.6	4.9	5.2	4.6	4.9	5.2	4.6	4.9	5.2	4.6	4.9				
50	50.3	6.9	7.3	7.7	35.6	0.94	38.3	0.79	5.6	5.95	6.3	5.6	5.95	6.3	50.9	1.06	5.8	6.15	6.5	5.8	6.15	6.5	5.8	6.15	6.5	5.8	6.15	6.5	5.8	6.15	6.5	5.8	6.15	6.5	5.8	6.15				
63	63.4	8.6	9.1	9.6	45	1.48	48.1	1.26	7.1	7.55	8.0	7.1	7.55	8.0	60.9	1.47	7.4	7.8	8.2	7.4	7.8	8.2	7.4	7.8	8.2	7.4	7.8	8.2	7.4	7.8	8.2	7.4	7.8	8.2	7.4	7.8				
75	75.5	10.3	10.9	11.5	53.5	2.11	57.5	1.78	8.4	8.9	9.4	8.4	8.9	9.4	72.9	2.13	8.6	9.0	9.4	8.6	9.0	9.4	8.6	9.0	9.4	8.6	9.0	9.4	8.6	9.0	9.4	8.6	9.0	9.4	8.6	9.0				
90	90.6	12.3	13	13.7	64.3	3.02	69.3	2.56	10.1	10.7	11.3	10.1	10.7	11.3	89.3	3.17	10	10.55	11.1	10	10.55	11.1	10	10.55	11.1	10	10.55	11.1	10	10.55	11.1	10	10.55	11.1	10	10.55	11.1	10	10.55	
110	110.7	15.1	15.95	16.8	78.5	4.53	84.4	3.81	12.3	13	13.7	12.3	13	13.7	101.3	4.11	11.4	12.05	12.7	11.4	12.05	12.7	11.4	12.05	12.7	11.4	12.05	12.7	11.4	12.05	12.7	11.4	12.05	12.7	11.4	12.05	12.7	11.4	12.05	
125	125.8	17.1	18.05	19	89.3	5.83	95.8	4.93	14.0	14.8	15.6	14.0	14.8	15.6	113.7	5.12	12.7	13.4	14.1	12.7	13.4	14.1	12.7	13.4	14.1	12.7	13.4	14.1	12.7	13.4	14.1	12.7	13.4	14.1	12.7	13.4	14.1	12.7	13.4	
140	140.9	19.2	20.25	21.3	100.0	7.33	107.4	6.17	15.7	16.55	17.4	15.7	16.55	17.4	129.7	6.72	14.6	15.4	16.2	14.6	15.4	16.2	14.6	15.4	16.2	14.6	15.4	16.2	14.6	15.4	16.2	14.6	15.4	16.2	14.6	15.4	16.2	14.6	15.4	
160	161	21.9	23.05	24.2	114.4	9.53	122.8	8.04	17.9	18.85	19.8	17.9	18.85	19.8	146.0	8.50	16.4	17.3	18.2	16.4	17.3	18.2	16.4	17.3	18.2	16.4	17.3	18.2	16.4	17.3	18.2	16.4	17.3	18.2	16.4	17.3	18.2	16.4	17.3	
180	181.1	24.6	25.9	27.2	128.8	12.05	138.2	10.17	20.1	21.2	22.3	20.1	21.2	22.3	162.2	10.48	18.2	19.2	20.2	18.2	19.2	20.2	18.2	19.2	20.2	18.2	19.2	20.2	18.2	19.2	20.2	18.2	19.2	20.2	18.2	19.2	20.2	18.2	19.2	
200	201.2	27.4	28.85	30.3	142.9	14.91	153.4	12.57	22.4	23.6	24.8	22.4	23.6	24.8	182.2	12.57	20.5	21.6	22.7	20.5	21.6	22.7	20.5	21.6	22.7	20.5	21.6	22.7	20.5	21.6	22.7	20.5	21.6	22.7	20.5	21.6	22.7	20.5	21.6	
225	226.4	30.8	32.4	34	160.9	18.85	172.6	15.91	25.2	26.55	27.9	25.2	26.55	27.9	203.0	15.91	22.7	23.9	25.1	22.7	23.9	25.1	22.7	23.9	25.1	22.7	23.9	25.1	22.7	23.9	25.1	22.7	23.9	25.1	22.7	23.9	25.1	22.7	23.9	
250	251.5	34.2	36	37.8	178.8	23.27	192.1	19.56	27.9	29.35	30.8	27.9	29.35	30.8	227.4	19.56	25.2	26.55	27.9	25.2	26.55	27.9	25.2	26.55	27.9	25.2	26.55	27.9	25.2	26.55	27.9	25.2	26.55	27.9	25.2	26.55	27.9	25.2	26.55	
280	281.7	38.3	40.3	42.3	200.3	28.18	215.0	24.58	31.3	32.95	34.6	31.3	32.95	34.6	258.2	24.58	28.2	29.5	30.8	28.2	29.5	30.8	28.2	29.5	30.8	28.2	29.5	30.8	28.2	29.5	30.8	28.2	29.5	30.8	28.2	29.5	30.8	28.2	29.5	
315	316.9	43.1	45.35	47.6	225.3	36.93	241.9	31.10	35.2	37.05	38.9	35.2	37.05	38.9	288.3	31.10	32.2	33.9	35.6	32.2	33.9	35.6	32.2	33.9	35.6	32.2	33.9	35.6	32.2	33.9	35.6	32.2	33.9	35.6	32.2	33.9	35.6	32.2	33.9	
355	357.2	48.5	51	53.5	254.1	46.83	272.6	39.50	39.7	41.75	43.8	39.7	41.75	43.8	344.4	39.50	36.3	38.2	40.1	36.3	38.2	40.1	36.3	38.2	40.1	36.3	38.2	40.1	36.3	38.2	40.1	36.3	38.2	40.1	36.3	38.2	40.1	36.3	38.2	
400	402.4	54.7	57.5	60.3	286.2	59.48	307.2	50.10	44.7	47	49.3	44.7	47	49.3	388.3	50.10	40.9	43	45.1	40.9	43	45.1	40.9	43	45.1	40.9	43	45.1	40.9	43	45.1	40.9	43	45.1	40.9	43	45.1	40.9	43	
450	452.7	61.5	64.65	67.8	322.1	75.24	345.6	63.44	50.3	52.9	55.5	50.3	52.9	55.5	428.5	63.44	45.4	47.5	49.6	45.4	47.5	49.6	45.4	47.5	49.6	45.4	47.5	49.6	45.4	47.5	49.6	45.4	47.5	49.6	45.4	47.5	49.6	45.4	47.5	
500	503						384.2	78.17	55.8	58.65	61.5	55.8	58.65	61.5	481.6	78.17	48.4	50.8	53.4	48.4	50.8	53.4	48.4	50.8	53.4	48.4	50.8	53.4	48.4	50.8	53.4	48.4	50.8	53.4	48.4	50.8	53.4	48.4	50.8	
560	563.4						430.3	98.08	62.5	65.7	68.9	62.5	65.7	68.9	545.3	98.08	52.2	54.9	57.6	52.2	54.9	57.6	52.2	54.9	57.6	52.2	54.9	57.6	52.2	54.9	57.6	52.2	54.9	57.6	52.2	54.9	57.6	52.2	54.9	
630	633.8						484.1	124.10	70.3	73.9	77.5	70.3	73.9	77.5	602.2	124.10	61.7	64.8	67.9	61.7	64.8	67.9	61.7	64.8	67.9	61.7	64.8	67.9	61.7	64.8	67.9	61.7	64.8	67.9	61.7	64.8	67.9	61.7	64.8	
710	716.4						545.3	158.00	79.3	83.35	87.4	79.3	83.35	87.4	682.6	158.00	73.5	76.2	79.3	73.5	76.2	79.3	73.5	76.2	79.3	73.5	76.2	79.3	73.5	76.2	79.3	73.5	76.2	79.3	73.5	76.2	79.3	73.5	76.2	
800	807.2						623.4	200.47	89.3	93.65	98.4	89.3	93.65	98.4	790.3	200.47	81.7	85.85	90	81.7	85.85	90	81.7	85.85	90	81.7	85.85	90	81.7	85.85	90	81.7	85.85	90	81.7	85.85	90	81.7	85.85	
900	908.1														812.4	259.55	90.2	94.8	99.4	90.2	94.8	99.4	90.2	94.8	99.4	90.2	94.8	99.4	90.2	94.8	99.4	90.2	94.8	99.4	90.2	94.8	99.4	90.2	94.8	
1000	1009.0																																							

Ongoing engineering design efforts may affect the technical information listed in our publications.

HYDRAULIC BUTT WELDING MACHINE

INTRODUCTION

This is the manual for PSA40-160 | PSA50-200 | PSA50-250 | PSA90-315 | PSA90-355 | PSA200-450 | PSA315-630 | PSA450-800 and PSA630-1000 butt fusion welding machines, please read it carefully. Please handle and maintain the machine according to this manual.

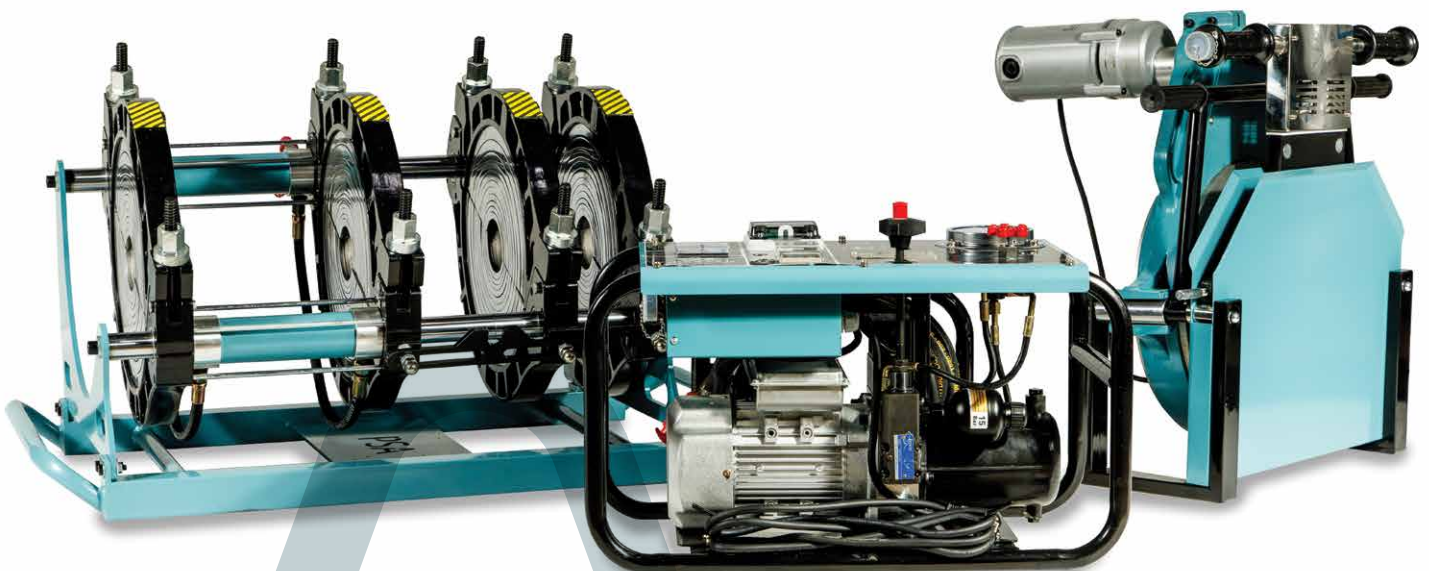

TECHNICAL PARAMETERS



PIPESTAR
AFRICA

TECHNICAL PARAMETERS

Model NO.		PSA40-160	PSA50-200	PSA50-250	PSA90-315	PSA90-355
Application Materials		PE/PP/PVDF				
Welding Range		40~160mm	50~200mm	50~250mm	90~315mm	90~355mm
Ambient Temperature		-5~45°C				
Voltage		220V±10%,50HZ				
Total Power		3.55kw	3.95kw	5.75kw	6.25kw	6.75kw
Heating Plate		1.6kw	2kw	2.5kw	3kw	3.5kw
Trimmer		1.2kw	1.2kw	2.5kw	2.5kw	2.5kw
Hydraulic Unit		0.75kw	0.75kw	0.75kw	0.75kw	0.75kw
Insulation Resistance to earth		>1 MΩ	>1 MΩ	>1 MΩ	>1 MΩ	>1 MΩ
Max. Pressure		6.3MPa	6.3MPa	6.3MPa	6.3MPa	>6.3MPa
Total area of hydraulic cylinders		11.00cm ²	11.00cm ²	11.00cm ²	20.02cm ²	20.02cm ²
Type of hydraulic oil		Type 46 hydraulic oil				
Oil tank capacity		3L				
Max. Temperature		<270°C				
Temp. difference on heater		±5°C				
Frame	Size (cm)	82*44*40	85*48*44	85*53*43	94*62*60	94*64*62
	Weight (kg)	38	42	52	80	112.3
Hydraulic Unit	Size (cm)	58*47*47	58*47*47	58*47*47	58*47*47	58*47*47
	Weight (kg)	41.5	41.5	41.5	41.5	41.5
Trimmer	Size (cm)	31*24*32	35*36*35	36*47*47	59*38*58	60*39*63
	Weight (kg)	6	7	17.5	22	32
Heating Plate	Size (cm)	37*5*35	37*5*40	44*5.5*47	44*5*53	50*6*57
	Weight (kg)	3	3.8	5.5	7.8	10.3
Support	Size (cm)	30*18.5*42	33.5*18.5*46	39*28*56.5	48*28.5*56.5	52*29*59
	Weight (kg)	1.5	2.1	2.6	3.5	5.9
Total weight (kg)		90	96.4	119.1	154.8	255

TECHNICAL PARAMETERS

Model NO.		PSA200-450	PSA315-630	PSA450-800	PSA630-1000
Application Materials		PE/PP/PVDF			
Welding Range		200~450mm	315~630mm	450~800mm	630~1000mm
Ambient Temperature		-5~45°C			
Voltage		380V±10%,50HZ			
Total Power		7.8KW	11.8KW	17KW	23.2KW
Heating Plate		5.2KW	9.2 KW	12.8KW	18KW
Trimmer		1.5KW	1.5KW	2.2KW	3KW
Hydraulic Unit		1.1KW	1.1KW	2KW	2.2KW
Total area of hydraulic cylinders		22.37cm ²	23.06cm ²	43.96cm ²	50.24cm ²
IP Level		IP54			
Insulation Resistance to earth		>1 MΩ			
Max. Pressure		6.3Mpa		10Mpa	
Oil tank capacity		3L		6L	
Type of hydraulic oil		Type 46 hydraulic oil			
Max. Temperature		<270°C			
Temp. difference on heater		±7°C			
Frame	Size (cm)	120*74*79	131*97*92	175*130*128	200*160*160
	Weight (kg)	200	330	802	1300
Hydraulic Unit	Size (cm)	58*46*45	58*46*45	74*50*45	74*50*45
	Weight (kg)	49	49	52	52
Trimmer	Size (cm)	63*16*98	78*29*109	97*36*150	110*34*170
	Weight (kg)	59	103	202	320
Heating Plate	Size (cm)	71*10*70	91*7*100	98*9*104	122*10*135
	Weight (kg)	16	34	61	84
Support	Size (cm)	50*50*60	63*58*71	81*67*90	117*76*99
	Weight (kg)	12	14	48	110
Total weight (kg)		400Kg	645Kg	1345Kg	2100 Kg

SPECIAL INSTRUCTIONS

Before operating the machine, the user should read this user manual to ensure the equipment and operator's safety, as well as the safety of others:

1. The machine is used to weld pipes made from PE, PP, PVDF and should not be used to weld material that cannot be identified, otherwise the machine may be damaged, and accidents may occur;
2. Don't use the machine in a place with flammable or explosive hazards.
3. The machine should be operated by responsible, qualified and trained personnel;
4. The machine should be operated on a dry area. Protective measures should be adopted when used in wet conditions.
5. Note that the Voltage of PSA160-PSA355 is 220V±10% / 50HZ Voltage of PSA400-PSA1000 is 380V±10% / 50Hz.
6. Before using the machine, fill the hydraulic oil reservoir with 46# hydraulic oil. Make sure the hydraulic oil is sufficient for smooth operation. Replace the metal oil tank cap by the red plastic air bleed cap provided



SAFETY SUGGESTIONS

The welding machine - should be operated by professional and certified personnel. Non-professional use of equipment may pose a hazard to operators and people around them.

Heating plate - The Heating plate temperature can reach 270°C, please take the necessary precautions to prevent burns such as wearing protective gloves. Once pipe heating is completed return the heating plate to the frame for storage.

Trimming Cutter - Before trimming pipe or fittings ends, ensure that pipe and fittings surfaces are clean in order to prevent damage to the trimmer blades. Once trimming is completed, the trimmer should be returned to the frame for storage.

Hydraulic Unit - The hydraulic unit should be placed so as to avoid a tripping hazard. Hydraulic seals should be inspected regularly to ensure that there are no leakages of hydraulic oil. All debugging should be performed by a qualified professional.

Clamping Frame - Ensure that prior to welding pipe and fittings to be welded are properly seated and secure. Ensure screws that hold aluminium clamp inserts in place are properly fastened.

Crane Use - 315 - 630 / 450 - 800 / 630 - 1000.

Crane assembly should only be done by qualified and competent persons.



INSTRUCTIONS FOR USE

All parts of equipment should be placed on a stable and dry area to operate.

Before operation ensure the following:

- ✓ The machine is in a working good condition;
- ✓ The power supply complies with the requirements according to the butt fusion machine;
- ✓ Electrical wires are not broken or exposed;
- ✓ All instruments are functioning normally;
- ✓ The blades of trimmer tool are sharp;
- ✓ All necessary parts and tools are available.

Connection and preparation:

1. Connect the hydraulic cylinder on the frame to hydraulic unit by quick couplers;
2. Connect the heating plate to the hydraulic unit with the special cable;
3. Connect the hydraulic unit with the electrical box;
4. Connect electrical supply to the trimmer;
5. Install appropriate inserts to clamping frame according to the outside diameter of pipes/fittings to be welded, ensure clamps are securely fastened.



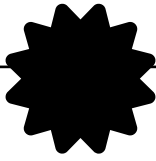

Welding Standard

We suggest that welding procedures are performed in compliance with SANS 10268 -1 or DVS 2207-1.

Refer to the attached welding parameter tables for the specific machine in use.

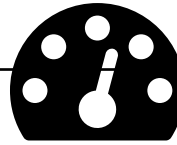

Temperature Controller

Setting of the temperature controller

Application

1. Press "SET" for more than 3 seconds till "sd" is shown in the upper window;
2. Press "▲" or "▼" to change the value to specified (press "▼" or "▲" continuously, the value will plus or minus automatically);
3. After setting, press "SET" to go back to the monitoring and controlling interface.

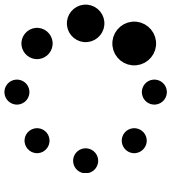

Timer setting and use

If one of the parameters is changed, such as outside diameter, SDR or material of pipes, the soaking time and cooling time should be reset according to the welding parameters.

TIMER SETTING

Select "set"	Lamp T2 is on and Lamp T5 is off
Select ▲ or ▼	To set soaking time in seconds
Select "set"	The lamp T2 is off and Lamp T5 is on
Select ▲ or ▼	To set cooling time in seconds
Select "set"	Timer setting is over

INSTRUCTION FOR TIMER USE

Select T2	<ul style="list-style-type: none"> • The soaking time is counted in seconds, and the alarm will sound once completed. • Alarm stops after 5 seconds - intermittent tone
Select T5	<ul style="list-style-type: none"> • The cooling time is counted in seconds and the alarm will sound once completed. • Alarm stops after 8 seconds - long tone.
Select ▲ or ▼	Timer stops



001/007410

UNE-EN 12201-1:2012 (EN 12201-1:2011)
UNE-EN 12201-3:2012+A1:2013 (EN 12201-3:2011+A1:2012)



001/007409

ISO 4427-3:2007



0175/Rev 01

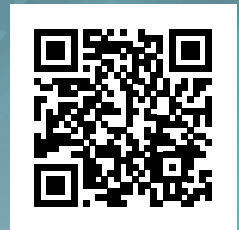

CONTACT

22 Old Vereeniging Road, Kliprivier,
Midvaal, South Africa, 1871
Tel: +27 87 655 4390

Registration Number: 1964/006605/07
VAT Number: 4170232781

 info@pipestarafrika.com
 www.pipestarafrika.com